

Tap holders for synchronized tapping cycles

Synchronized Tapping



SynchroFlex® – Force vs. Deflection Rates

Unlike competitors that employ elastomer rings to provide a small amount of axial compensation (± 0.5 mm), the SynchroFlex® flexure has a consistent force vs. deflection rate. This means consistently superior tap life and thread quality.

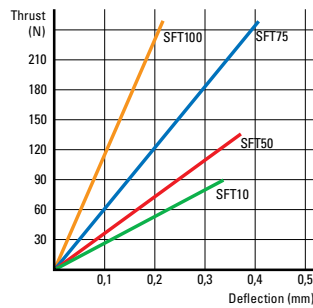

Axial micro compensation is closely limited (mechanically secured)

Torque is transmitted through the drive pins – not through the flexure.

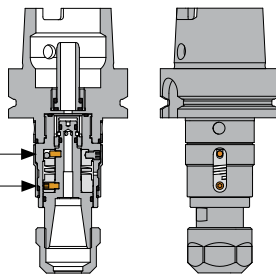

Design and Development

Flexure geometries have been designed using the ANSYS finite element analysis method in order to achieve the optimal force vs. deflection rates for the tap capacity of each holder.

As you can see from the cross section drawing, torque is transmitted through the drive pins not through the flexure.

General Information

Modern CNC machines have the capability of synchronizing the spindle rotation to match the feed advance for a specific tap pitch. The «Rigid» or synchronized tapping cycle is very accurate, but it is impossible to avoid small discrepancies between the machine synchronization and the actual pitch of the specific tap being used. Using a rigid tap holder means that any deviation at all increases the thrust forces acting on the tap and this dramatically reduces tap life.

New SynchroFlex® II with increased flow rates for high pressure internal coolant.

SynchroFlex® – The Unique Solution

At the heart of SynchroFlex® is a precisely machined flexure which provides axial and radial compensation for the unavoidable discrepancy between the machine feed advance and the actual tap pitch. By compensating for this error, the thrust forces acting on the tap are dramatically reduced. The result is the longest possible tap life, 100% improvement or more, and much better quality threads.

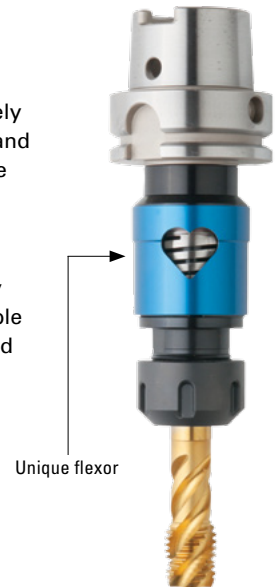

By limiting the axial compensation travel, and torsional forces acting on the flexure, millions of holes can be tapped without causing the SynchroFlex® holder to fatigue, take a set, or wear out. Below is an example of stress analysis at maximum compression.

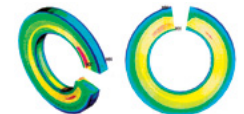

Comparison tapping with an M6 spiral fluted tap in 6061 Aluminum to depth of 18 mm.

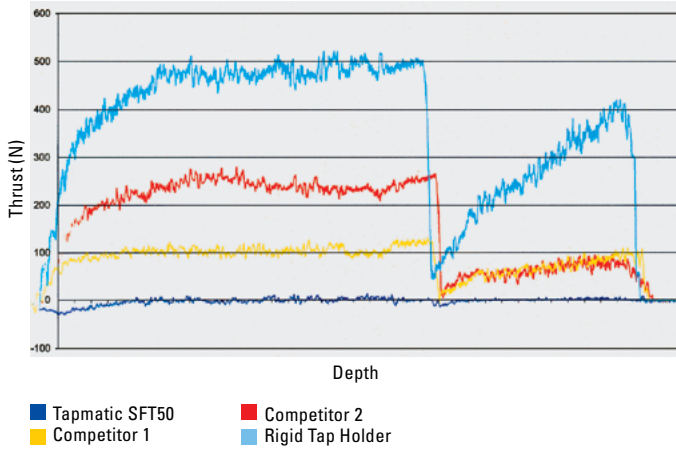

Test Results

SynchroFlex® tap holders have been tested by tap manufacturers all over the world and they have confirmed the dramatic improvement in tap life, and thread quality resulting from the reduction of thrust forces acting on the tap.

The graph to the left is an example of a test conducted by an independent tap manufacturer using a Kistler dynamometer to measure the thrust forces during the tapping process. As you can see from the graph, although the competitive holders do reduce thrust forces compared to a rigid tap holder, they are not as effective as SynchroFlex®.

Case History

Application: Thread cutting on horizontal machining center rigid tapping during an unmanned shift.

Material: 42CrMo4V steel, heat treated to 650 N/mm²

Tap Size: M8 x 1

Lubrication: Coolant, oil emulsion 6%

Results: With the tap held in a rigid holder the life was just 1'000 components per tap.

Improvement with SynchroFlex®

Tap life increased to 2'400 to 2'900 components per tap saving the customer not only in tap costs, but the ability to run without interruption through the entire unmanned shift.

Case History

Application: Thread cutting on machining center rigid tapping.

Material: CF8M steel casting

Tap Size: #10-32

Lubrication: Coolant

Results: With the tap held in a rigid holder the life was just 72 holes per tap.

Improvement with SynchroFlex®

Tap life increased to more than 216 holes per tap in this difficult material saving the customer not only in tap costs, but by also reducing his down time caused by frequent tap replacement.

Total cost/year

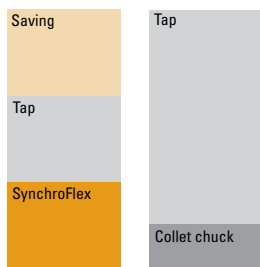

Break Even Point

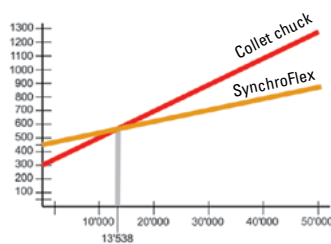

Evaluation of economic efficiency

Costs	SynchroFlex chuck	Collet chuck without compensation
Number of threads / year	50'000	50,000
Number of threads / tap	2'400	1,000
Number of taps / year	21	50
Price / tap in \$	26	26
Tap costs in \$	546	1,300
Chuck costs in \$ (approx.)	600	405
Total costs in \$ / year	1,146	1,705
Cost reduction in \$ / year	559	

Total cost/year

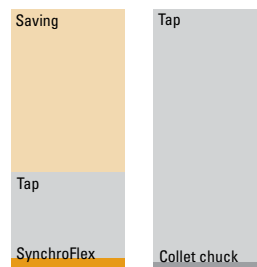

Break Even Point

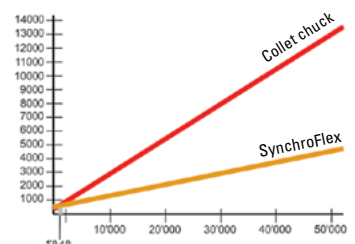

Evaluation of economic efficiency

Costs	SynchroFlex chuck	Collet chuck without compensation
Number of threads / year	50,000	50,000
Number of threads / tap	216	72
Number of taps / year	231	695
Price / tap in \$	26	26
Tap costs in \$	6,006	18,070
Chuck costs in \$ (approx.)	600	405
Total costs in \$ / year	6,606	18,475
Cost reduction in \$ / year	11,869	

Overview of the SynchroFlex® program



Pictured with ER-collet, spindle and straight shank

Six Sizes to Cover a Wide Range of Taps

- SFT II 5 with capacity M1–M3
- SFT II 10 with capacity M2–M5
- SFT II 50 with capacity M4–M12
- SFT II 75 with capacity M8–M20
- SFT II 100 with capacity M16–M30
- SFT II 150 with capacity M22–M48

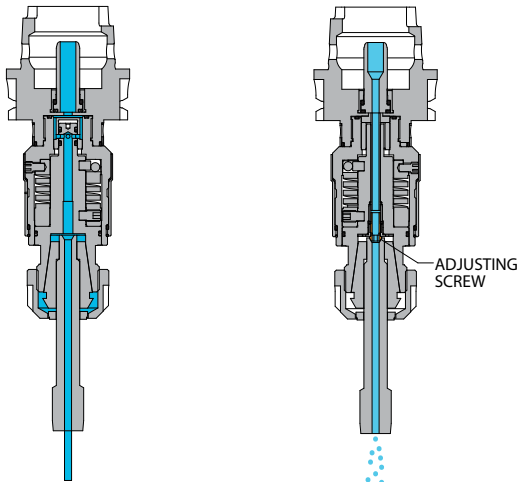

SFT II
High Pressure Internal Coolant
with increased flow rates

Minimum Quantity Lubrication
Available for 1 channel or
Multi channel systems

Internal Coolant and MQL

Tapmatic's high pressure internal coolant system may be used at pressures up to 80 bar without affecting the axial compensation.

Tapmatic also can provide tools ready for Minimum Quantity Lubrication through the spindle. Our system provides direct flow of air and lubricant to the back of the tap. See page 23.

Available with QC spindle

Accepts the standard Quick Change adapters or Tapmatic's ER collet chuck QC adapters for improved tap grip.



Integral shank models

Tapmatic offers standard integral shank HSK and Tapmatic Capto tools. ABS shanks are also available on request.



We can also offer integral Steep Taper shank tools but in most cases we recommend a modular system using a cylindrical shank SynchroFlex® together with our Short Projection SK, BT or CAT shank.

No hole beyond your reach

Four standard extensions are available which increase the tool length by 50, 100, 150, or 200 mm.

Special extensions are also available to fit your specific application. Our extensions keep the flexure in close proximity to the tap ensuring the best performance.



Synchronous feed tap holders with modular straight shank, with internal coolant system



ER Collet Chuck



Quick-Change

Features and Advantages

- increase tap life by 100% or more
- improves thread quality
- reduces downtime by lowering frequency of tap replacement
- Axial compensation +/- 0.5mm (SFT II 150 +/- 1.5mm)
- wide range of sizes
- available with ER collet or Quick Change chuck
- available with high pressure internal coolant system up to 80 bar (Balanced Coolant System)

How to Order

Please select the tap holder (A) and SK or BT shank (B), to fit your machine. For Quick Change models order ER collet adapter (C) shown below or standard adapters shown in accessories section. Please order accessories like collets and sealing gaskets separately as they are not included.

(A) Tap Holder SFTII Cylindrical Shank, ER Collet Chuck, Internal Coolant System

Model	Order code (with seal nut)	Capacity (steel)	Shank	Collets	Weight kg	D	D1	d	L (with seal nut)	Order code (nut w/o seal)	L (nut w/o seal)
SFT II 5		M1-M3 #00-#5	12 mm	ER8	0.1	12.0	12.0	12		41051208	28
SFT II 10		M2-M5 #2-#10	25 mm	ER11	0.4	23.5	23.5	19		41102511	52
	1"		41101111								
	20 mm		41102011								
			16 mm						41101611		
SFT II 50	41502520	M4.5-M12 #8-1/2"	25 mm	ER20	0.5	34.6	36.3	34	69	41502520N	64
	4150120		4150120N								
	41502020		41502020N								
SFT II 75	41752525	M8-M20 1/4"-3/4"	25 mm	ER25	1.0	44.0	45.6	42	88	41752525N	83
	4175125		4175125N								
SFT II 100	411002540	M16-M30 5/8"-1"	25 mm	ER40	2.0	62.0	63.6	63	117	411002540N	112
	41100140		41100140N								
SFT II 150	411504050	M22-M48 * 7/8"-1 7/8"	40 mm	ER50	5.1	80.0	86.0	78	166	411504050N	159

*Note: Availability of inch size ER50GB collets is limited. Please consult a Tapmatic sales representative for sizes currently available. These internal coolant tools come standard with sealing nut, but tools with standard nuts are also available. When using Roll Form Taps the tool's capacity must be reduced 25%. All dimensions are shown in mm. 25.4mm = 1".

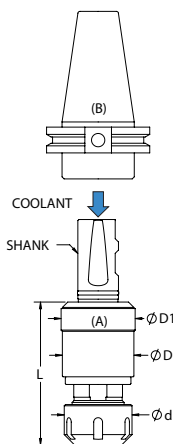

(A) Tap Holder SFTII Cylindrical Shank, Quick-Change Internal Coolant System

Model	Order code	Capacity (steel)	Shank	Adapter	Weight kg	D	D1	d	L
SFT II 50	415025QC	M4-M12 #8-#1/2"	25 mm	Nr. 1	0.5	34.6	36.3	35	56
	41501QC		1"						
SFT II 75	417525QC	M8-M16 #1/4"-5/8"	25 mm	Nr. 1	1.0	44.0	45.6	40	72
	41751QC		1"						
SFT II 100	4110025QC	M16-M30 1/2"-7/8"	25 mm	Nr. 2	2.0	62.0	63.6	59	105
	411001QC		1"						

Note: When using Roll Form Taps the tool's capacity must be reduced 25%. All dimensions are shown in mm. 25.4mm = 1". For best performance we recommend ER collet adapters shown below.

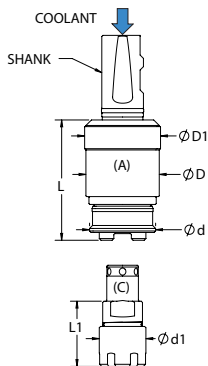

(C) ER collet adapter

Order code with Standard Nut	Adapter	Collets	d1	L1	Order code with Seal Nut for BCS version	L1 (BCS)
8208216	Nr. 1	ER16	22	24	8208216S	28
8218220	Nr. 1	ER20	28	35	8218220S	40
8288225	Nr. 2	ER25	35	38	8288225S	43
8288232	Nr. 2	ER32	50	48	8288232S	53

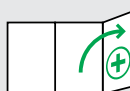

Synchronous feed tap holders with integral HSK shank, with internal coolant system

Synchronized Tapping



Features and Advantages

- increase tap life by 100% or more
- improves thread quality
- reduces downtime by lowering frequency of tap replacement
- Axial compensation +/- 0.5mm
- wide range of sizes
- available with ER collet or Quick Change chuck
- available with high pressure internal coolant system up to 80 bar. (Balanced Coolant System)
- also available for Minimum Quantity Lubrication (MQL) through the spindle. Please see page 23

How to Order

Please select the tap holder (A) including the HSK shank, to fit your machine. For Quick Change models order ER collet adapter (C) shown below or standard adapters shown in Accessories section. Please order accessories like collets and sealing gaskets separately as they are not included.

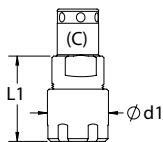
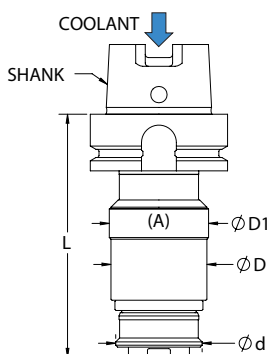
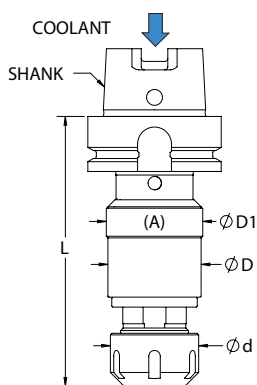

(A) Tap Holder SFT HSK Shank, ER Collet Chuck, Internal Coolant System

Model	Order code (with seal nut)	Capacity (steel)	Shank	Collets	Weight kg	D	D1	d	L
SFT II 50	4150H6320	M4-M12	HSK63A	ER20	1.0	34.6	36.3	34	108
	4150H8020	#8-1/2"	HSK80A		1.9				113
	4150H10020		HSK100A		2.7				115
SFT II 75	4175H6325	M8-M20	HSK63A	ER25	1.6	44.0	45.6	42	128
	4175H8025	1/4"-3/4"	HSK80A		2.4				131
	4175H10025		HSK100A		3.2				133
SFT II 100	41100H6340	M16-M30	HSK63A	ER40	2.2	62.0	63.6	63	160
	41100H8040	5/8"-1"	HSK80A		2.9				161
	41100H10040		HSK100A		3.7				163

Note: These internal coolant tools come standard with sealing nut, but tools with standard nuts are also available. When using Roll Form Taps the tool's capacity must be reduced 25%. All dimensions are shown in mm. 25.4mm = 1".

(A) Tap Holder SFTII HSK Shank, Quick-Change, Internal Coolant System

Model	Order code	Capacity (steel)	Shank	Adapter	Weight kg	D	D1	d	L
SFT II 50	4150H63QC	M4-M12	HSK63A	Nr. 1	1.0	34.6	36.3	35	95
	4150H80QC	#8-1/2"	HSK80A		1.9				100
	4150H100QC		HSK100A		2.7				102
SFT II 75	4175H63QC	M8-M16	HSK63A	Nr. 1	1.6	44.0	45.6	40	112
	4175H80QC	1/4"-5/8"	HSK80A		2.4				115
	4175H100QC		HSK100A		3.2				117
SFT II 100	41100H63QC	M16-M30	HSK63A	Nr. 2	2.2	62.0	63.6	59	148
	41100H80QC	1/2"-7/8"	HSK80A		2.9				149
	41100H100QC		HSK100A		3.7				151

Note: When using Roll Form Taps the tool's capacity must be reduced 25%. All dimensions are shown in mm. 25.4mm = 1". For best performance we recommend ER collet adapters shown below.

(C) ER Collet Adapter

Order code with Standard Nut	Adapter	Collets	d1	L1	Order code with Seal Nut	L1
8208216	Nr. 1	ER16	22	24	8208216S	28
8218220	Nr. 1	ER20	28	35	8218220S	40
8288225	Nr. 2	ER25	35	38	8288225S	43
8288232	Nr. 2	ER32	50	48	8288232S	53



Synchronous feed tap holders with Tapmatic Capto shank, with internal coolant system

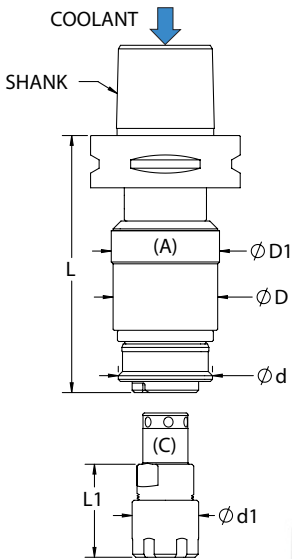
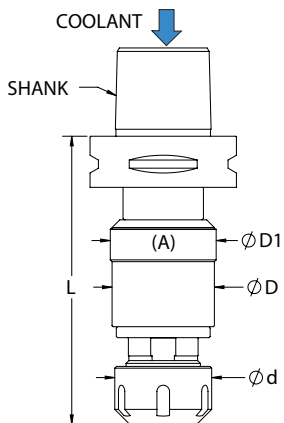

Features and Advantages

- increase tap life by 100% or more
- improves thread quality
- reduces downtime by lowering frequency of tap replacement
- Axial compensation +/- 0.5mm
- wide range of sizes
- available with ER collet or Quick Change chuck
- available with high pressure internal coolant system up to 80 bar. (Balanced Coolant System)

How to Order

Please select the tap holder (A) including the Tapmatic Capto shank, to fit your machine. For Quick Change models order ER collet adapter (C) shown below or standard adapters shown in Accessories section. Please order accessories like collets and sealing gaskets separately as they are not included.

(A) Tap Holder SFT II Tapmatic Capto Shank, ER Collet Chuck, Internal Coolant System

Model	Order code (with seal nut)	Capacity (steel)	Shank	Collets	Weight kg	D	D1	d	L
SFT II 50	4150C420	M4-M12	C4	ER20	0.7	34.6	36.3	34	102
	4150C520	#8-1/2"	C5		1.0				103
	4150C620		C6		1.2				105
	4150C820		C8		2.1				112
SFT II 75	4175C525	M8-M20	C5	ER25	1.2	44.0	45.6	42	122
	4175C625	1/4"-3/4"	C6		1.5				124
	4175C825		C8		2.4				131
SFT II 100	41100C640	M16-M30	C6	ER40	2.9	62.0	63.6	63	154
	41100C840	5/8"-1"	C8		3.8				161

Note: These internal coolant tools come standard with sealing nut, but tools with standard nuts are also available. Please add N to part number to specify nut without sealing. When using Roll Form Taps the tool's capacity must be reduced 25%. All dimensions are shown in mm. 25.4mm = 1"

(A) Tap Holder SFT II Tapmatic Capto Shank, Quick-Change, Internal Coolant System

Model	Order code	Capacity (steel)	Shank	Adapter	Weight kg	D	D1	d	L
SFT II 50	4150C4QC	M4-M12	C4	Nr. 1	0.7	34.6	36.3	35	89
	4150C5QC	#8-1/2"	C5		1.0				90
	4150C6QC		C6		1.2				92
	4150C8QC		C8		2.1				99
SFT II 75	4175C5QC	M8-M16	C5	Nr. 1	1.2	44.0	45.6	40	106
	4175C6QC	1/4"-5/8"	C6		1.5				108
	4175C8QC		C8		2.4				115
SFT II 100	41100C6QC	M16-M30	C6	Nr. 2	2.9	62.0	63.6	59	142
	41100C8QC	1/2"-7/8"	C8		3.8				149

Note: When using Roll Form Taps the tool's capacity must be reduced 25%. All dimensions are shown in mm. 25.4mm = 1". For best performance we recommend ER collet adapters shown below.

(C) ER Collet Adapter

Order code with Standard Nut	Adapter	Collets	d1	L1	Order code with seal nut	L1
8208216	Nr. 1	ER16	22	24	8208216S	28
8218220	Nr. 1	ER20	28	35	8218220S	40
8288225	Nr. 2	ER25	35	38	8288225S	43
8288232	Nr. 2	ER32	50	48	8288232S	53

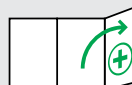

Synchronous feed tap holders with extended length, with internal coolant

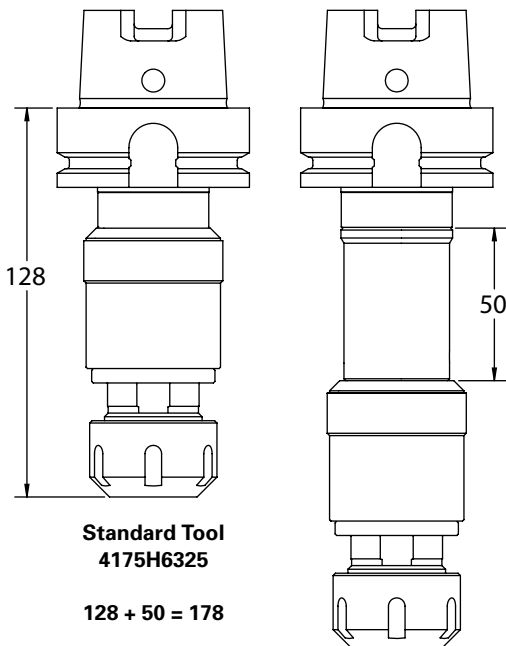

Standard Tool
4175H6325

$128 + 50 = 178$

Extended Tool
4175H63L17825

Features and Advantages

- four standard extensions of 50, 100, 150 and 200 mm
- increased tap life of 100% or more
- improved thread quality
- reduced downtime by lowering frequency of tap replacement
- Axial compensation +/- 0.5mm
- available with internal coolant pressure up to 80 bar

How to Order

Please select the standard length SFT50 or SFT75, including the integral shank of your choice. Then choose a standard extension of 50, 100, 150 or 200mm. The order code is given as shown in the example drawing at left. Accessories like steel collets and sealing gaskets are not included. Please order these separately.

Special length extensions are also available upon request.

Synchronized Tapping

Synchronous feed tap holders with reduced diameter and extended length

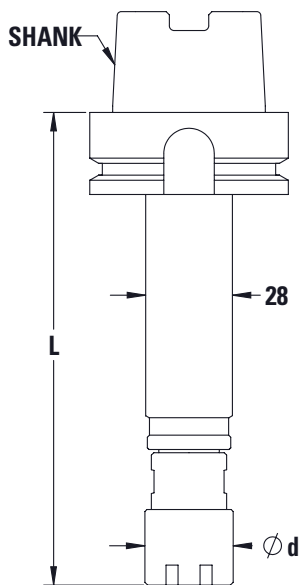

Features and Advantages

- special reduced diameter extended length tools for difficult to reach holes
- increased tap life of 100% or more
- improved thread quality
- reduced downtime by lowering frequency of tap replacement
- Axial compensation +/- 0.5mm
- available with internal coolant pressure up to 50 bar
- available with ER16 or ER20 mini nut collet chuck

How to Order

Please simply let us know the type of shank, length (L), and your preference of the ER16 or ER20 collet chuck. Please note diameter "d" for ER16 mini nut is 22mm and for ER20 it is 26mm. Accessories like steel collets and sealing gaskets are not included. Please order these separately.



Synchronous feed tap holders with integral HSK shank, with MQL, minimum quantity lubrication



Features and Advantages

- increase tap life by 100% or more
- improves thread quality
- precise lubrication delivery for improved tool life
- reduce coolant and maintenance costs
- environmentally friendly alternative to recirculating coolant
- standard for one channel system, but multi-channel also available

How to Order

Please select the tap holder (A) including the HSK shank, to fit your machine. Please order accessories like collets, adjusting screws and sealing gaskets separately as they are not included.

(A) Tap Holder SFTII HSK Shank, ER Collet Chuck, MQL, minimum quantity lubrication system

Model	Order code for MQL version	Capacity (steel)	Shank	Collets	Weight kg	D	D1	d	L
SFT II 50	4150H6320M	M4-M12	HSK63A	ER20	1.0	34.6	36.3	34	108
	4150H8020M	#8-1/2"	HSK80A		1.9				113
	4150H10020M		HSK100A		2.7				115
SFT II 75	4175H6325M	M8-M20	HSK63A	ER25	1.6	44.0	45.6	42	128
	4175H8025M	1/4"-3/4"	HSK80A		2.4				131
	4175H10025M		HSK100A		3.2				133

Note: These MQL tools come standard with sealing nut. When using Roll Form Taps the tool's capacity must be reduced 25%. All dimensions are shown in mm. 25.4mm = 1". Other shank sizes are also available

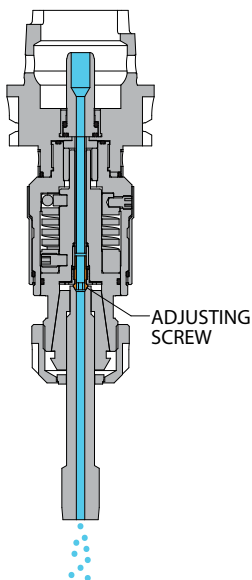
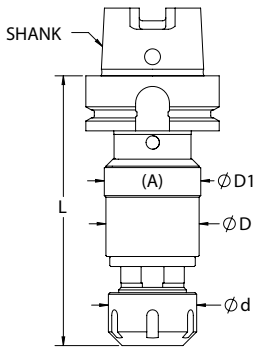

Adjusting Screws

Taps with External Center

Ø Tap Shank	SFT50II	SFT75II
6mm, 7mm	810836	
8mm, 9mm	810838	811838
10mm	8108310	8108310
11mm to 16mm		8118311

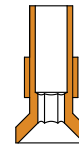

Taps with External Center

Taps with Internal Center

Ø Tap Shank	SFT50II	SFT75II
6mm, 7mm	810836IN	
8mm, 9mm	810838IN	811838IN
10mm	8108310IN	8108310IN
11mm to 16mm		8118311IN

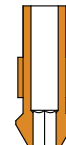

Taps with Internal Center

Additional sizes available on request.



Steel Collets



Sealing Gaskets

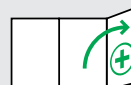

Selector Chart



Speed Chart



Programming